

- NOTES:
1. DIMENSIONS WITHIN THE PARENTHESES ARE METRIC UNITS (millimeters) or (Kg=Kilograms)
 2. MATERIAL: FIBERGLASS REINFORCED POLYMER (FRP)
 3. WEIGHT: 34 Lb. (15.4 Kg)

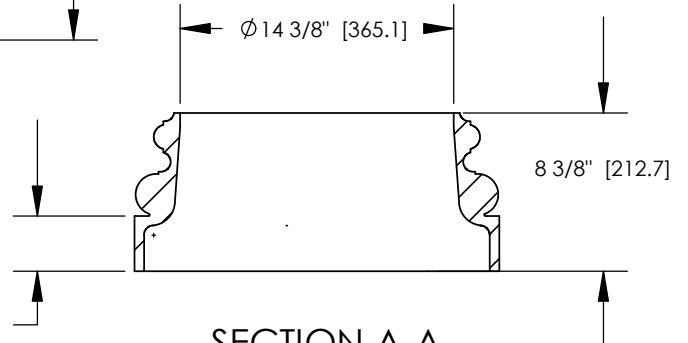

SECTION A-A
SCALE 1 : 10

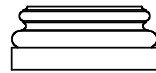
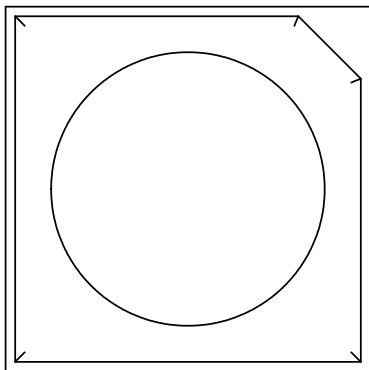
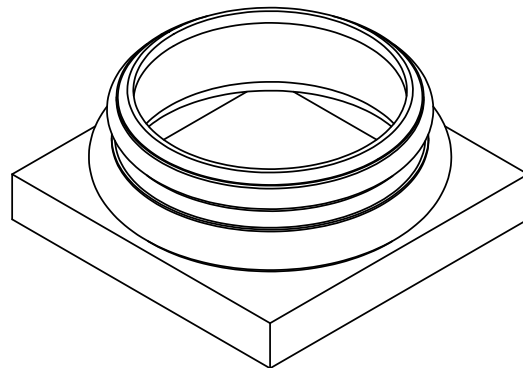
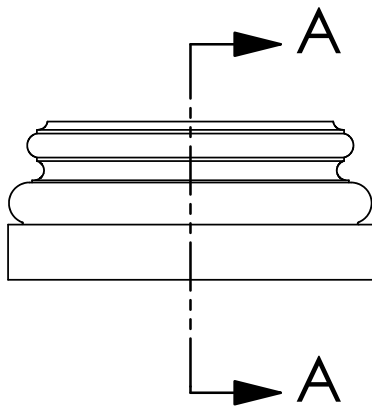

ARCHITECTURAL
VIEW
SCALE: 1/25

Column & Post, Inc.TM
8013 Purfoy Road
Fuquay-Varina, NC 27526
Tel: (919) 255-1533
Fax: (919) 255-1553
E-Mail: www.columnpost.com

		DIMENSIONS ARE IN INCHES TOLERANCES: FRACTIONAL ±1/8 ANGULAR: MACH ± BEND ± TWO PLACE DECIMAL ± THREE PLACE DECIMAL ±		NAME	DATE
			DRAWN	SOF	05/05/08
			CHECKED	RK	
			ENG APPR.	RK	
		MATERIAL	MFG APPR.	RK	
		FINISH	Q.A.	RK	
NEXT ASSY	USED ON		COMMENTS:		
APPLICATION		DO NOT SCALE DRAWING			

© COPYRIGHT
COLUMN & POST, Inc. 2002

ATTIC 14 INCH
BASE

SIZE	DWG. NO.	REV.
A		02
SCALE: 1/10	SHEET 1 OF 1	